

# Wall panel of the distribution box

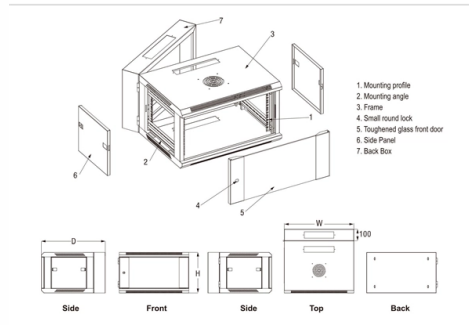

## Overview

This picture shows the interior of a typical distribution panel in the United Kingdom. The three incoming phase wires connect to the busbars via a main switch in the centre of the panel. On each side of the panel are two busbars, for neutral and earth. The incoming neutral connects to the lower busbar on the right side of the panel, which is in turn connected to the neutral busbar at the top left. OverviewA distribution board (also known as panelboard, circuit breaker panel, breaker panel, electric panel, fuse box or DB box) is a component of an that divides an electrical power feed into subsidiary. North American distribution boards are generally housed in enclosures, with the positioned in two columns operable from the front. Some panelboards are provided with a door covering th. Despite the adoption of a standard for mounting and a standard cut-out shape for seemingly interchangeable breakers, the positions of busbar connections and other features are not standardized. Each manufacturer.



## Article Content

### A Complete Guide to Distribution Boards

A distribution board or breaker panel separates incoming mains power into various sub-circuits. Usually, all the fuses, breakers and other circuit

### Distribution Boxes Types – The Complete Guide

The power distribution boxes deliver electricity from the main electrical main to other circuits. Several distribution boxes are designed for specific use in

### Distribution Box and Selection Guide

Distribution Box Selection Guide This guide provides information on how to select the appropriate Distribution Box for Electric project. If you have any

### Power Distribution Equipment

Mini Power-Zone: Mini Power-Zone combines a transformer and circuit breaker distribution panel into a single wall mounted substation. The substation includes a primary main circuit breaker, sealed step

### Panelboards and Distribution Panels: What They Are

A distribution panel (or distribution board) acts as an intermediary hub in the power distribution chain. It receives power from a main source, such as a

Discover Europe's digital cultural heritage | Europeana

Hier sollte eine Beschreibung angezeigt werden, diese Seite lässt dies jedoch nicht zu.

### Electrical Distribution Box: Complete Panel Types Guide

Learn what an electrical distribution box is in simple terms. Complete guide to panel types, NEC 408 requirements, and applications for home and

### Design Step-by-Step Guide for Power Distribution Panels

Outdoor distribution boxes should have rainproof facilities. 4. Management system of power distribution panel 4.1 Unrelated personnel are not

### The Complete Guide to Distribution Box: Installation, Types & More

What's the difference between a distribution box and a sub-panel? A distribution box typically refers to the main electrical panel that receives power from the utility service. A sub-panel is

### Panelboard fundamentals | load center vs. panelboard

A panelboard is a component of an electrical distribution system which divides an electrical power feed into branch circuits, while providing a protective circuit

### Power Distribution Boxes Explained Simply

Learn what a power distribution box is, how it works, key components, types, and why it's vital for safe and efficient electrical systems.

### What is an Electrical Distribution Box? A

What type of distribution box is best for a small business? For small businesses, a main circuit breaker panel with a sub-panel for specific high-load

### Distribution Boxes Explained: Types, Functions, and

Learn about distribution boxes, their types, functions, and safety features to ensure efficient and secure electrical power distribution in any building.

### Understanding Distribution Boxes: A Comprehensive Guide

A distribution box and an electrical panel are closely related, and in some markets the terms may overlap. In general, a distribution box is mainly

### Distribution Box Installation: A Complete Guide to Safe

The distribution box, often referred to as a breaker box, fuse box, or electrical panel, is a critical component of any electrical system. It acts as the central hub for

### Business Standard

Hier sollte eine Beschreibung angezeigt werden, diese Seite lässt dies jedoch nicht zu.

### What is an Electrical Distribution Box? A

Also known as a distribution board or breaker panel, it acts as the control hub, distributing power to different circuits and protecting them from

### Distribution Box: Types and Functions | Axis-Electricals

A distribution box ensures that electrical supply is distributed in the building, also known as a distribution board, panel board, breaker panel, or electric panel.

### Complete Guide For Distribution Boxes Types

Distribution boxes, also known as electrical distribution boards or panels, are pivotal components in electrical systems, ensuring the safe and organized distribution of

### Distribution boards components

Service cable ducts or conduits, surface mounted or in cable chases embedded in the wall Note: to facilitate future modifications to the installation, it is recommended to keep all relevant

## The Ultimate Guide to Distribution Box Types

Discover the key types of distribution boxes with NUOMAK's comprehensive guide. Learn about Main Distribution Boards (MDB), Consumer Units, Transfer

## The Complete Guide to Distribution Box: Installation, Types & More

A distribution box typically refers to the main electrical panel that receives power from the utility service. A sub-panel is a smaller distribution panel fed from the main panel to serve specific

## Distribution Board vs Distribution Box: Key Differences

A distribution board is a fixed electrical panel that divides power into circuits with protection; a distribution box is more compact or portable, used for

## The Basics of Panelboards For Electrical Engineers

The National Electrical Code® (NEC®) defines a panelboard as a single panel or group of panel units designed for assembly in the form of a single

## Distribution Boards

Distribution boards, often referred to as electrical panels or breaker boxes, serve as the nerve center of any electrical system. Here we explore the crucial parts of a distribution board and gain insights into

## Contact Us

For more information, pricing, or custom solutions, please contact us:

Website: <https://buglerdental.co.za>

Email: [sales@buglerdental.co.za](mailto:sales@buglerdental.co.za)

Phone: +27 71 549 2836

Address: 22 Impala Crescent, Waterfall Business Estate, Midrand, 1685, South Africa

This document is for informational purposes only. Specifications subject to change without notice.

